

HOBART

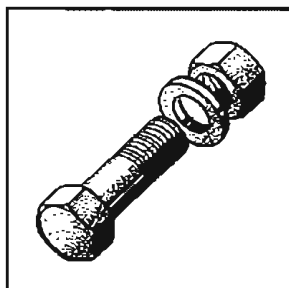

FM-300 U

Spare Parts
Pièces Détachées
Ersatzteile
Onderdelen



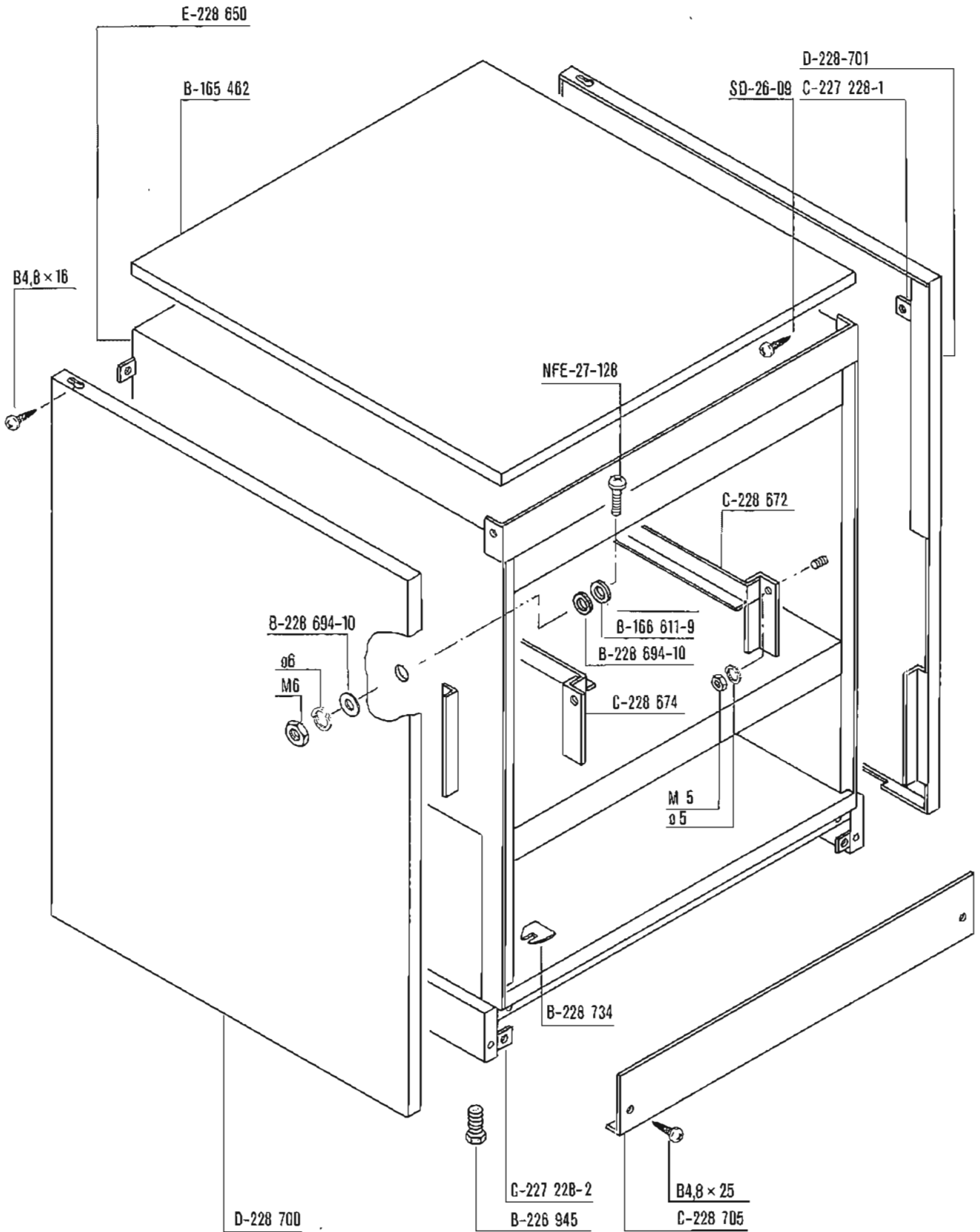

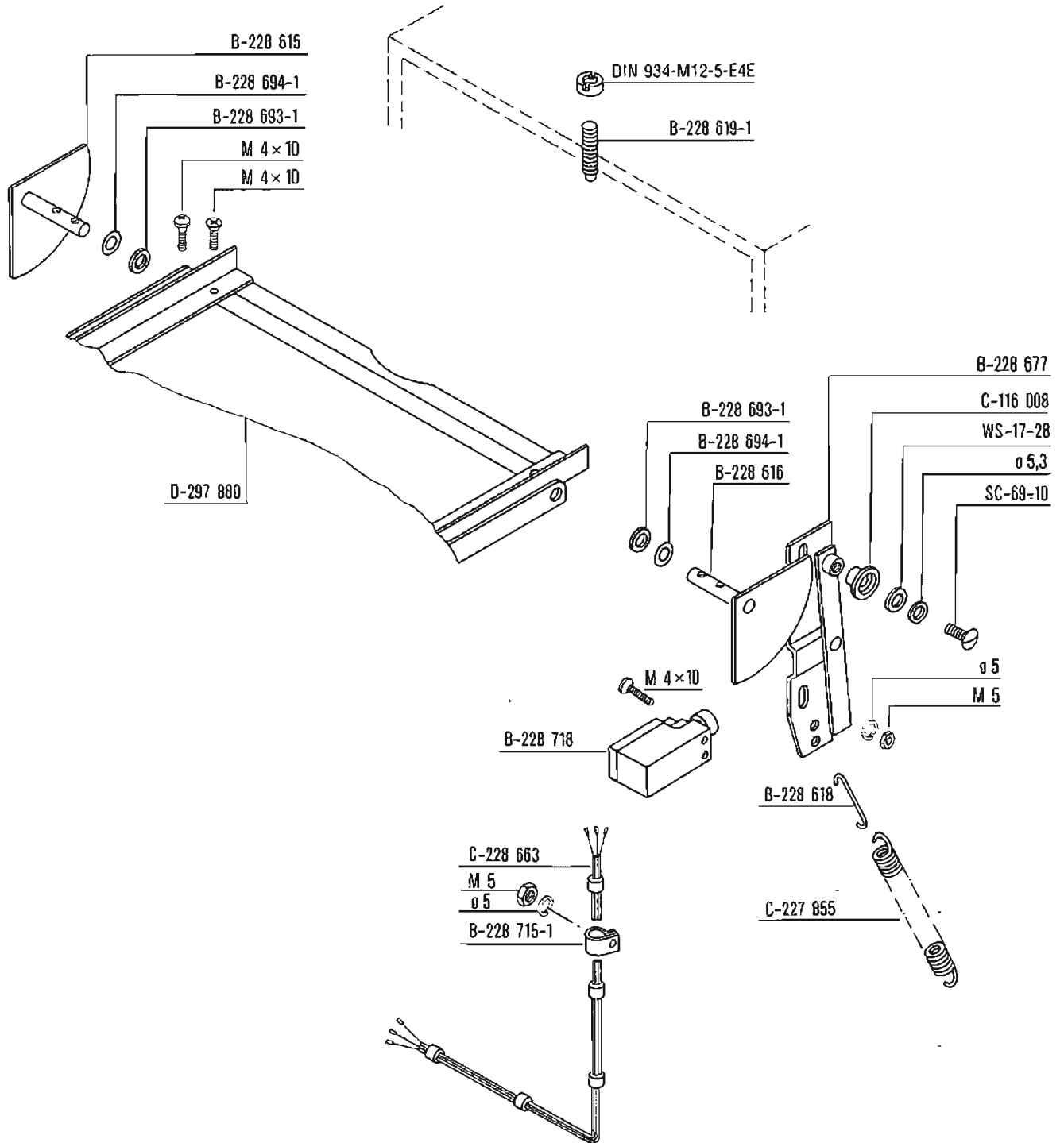

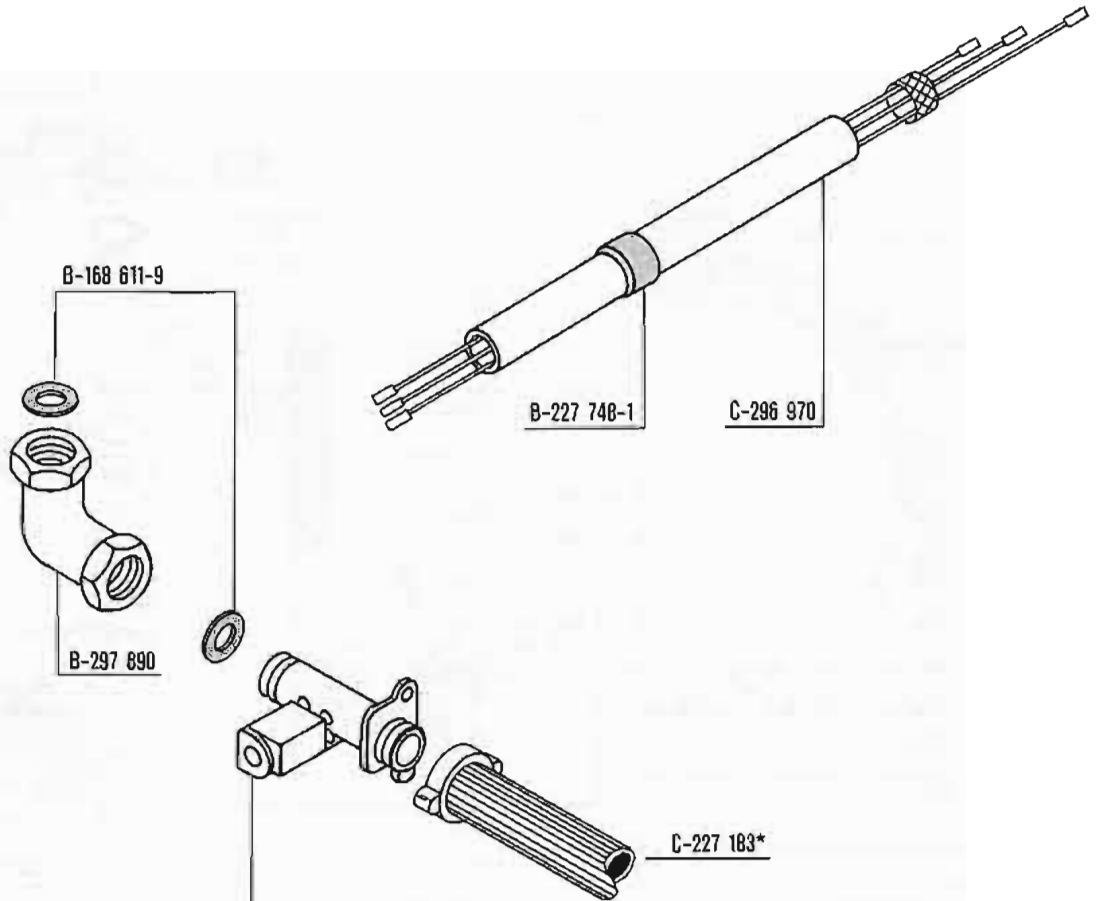

C-297 808-1	220/50/1	220/50/3	380/50/3/N
C-297 808-2	220/60/3		
C-297 808-3	240/50/1	240/50/3	415/50/3/N

*with drain pump only
 sit. avec pompe de vidange
 nur bei Ablaufpumpe

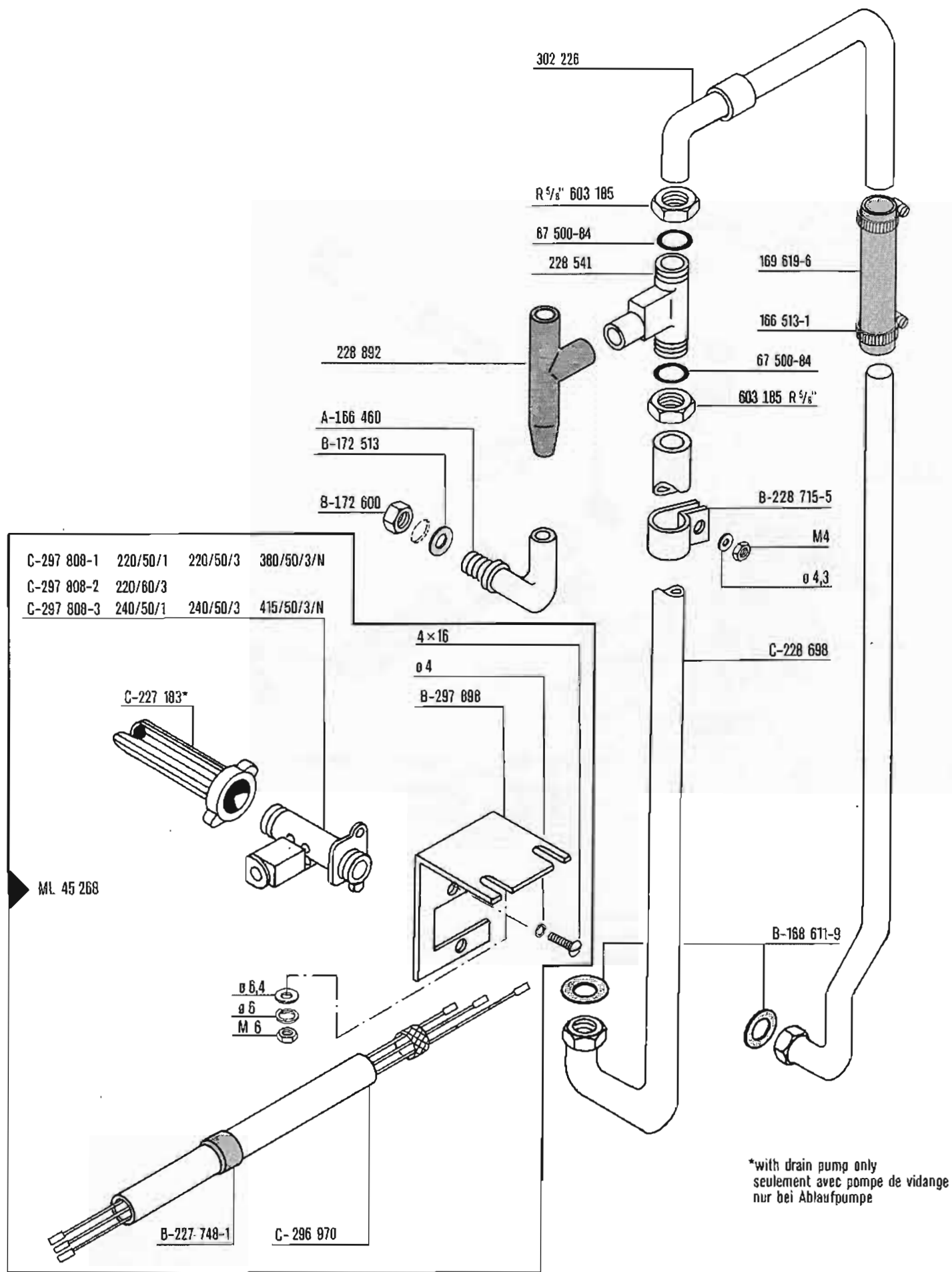

*with drain pump only
seulement avec pompe de vidange
nur bei Ablaufpumpe

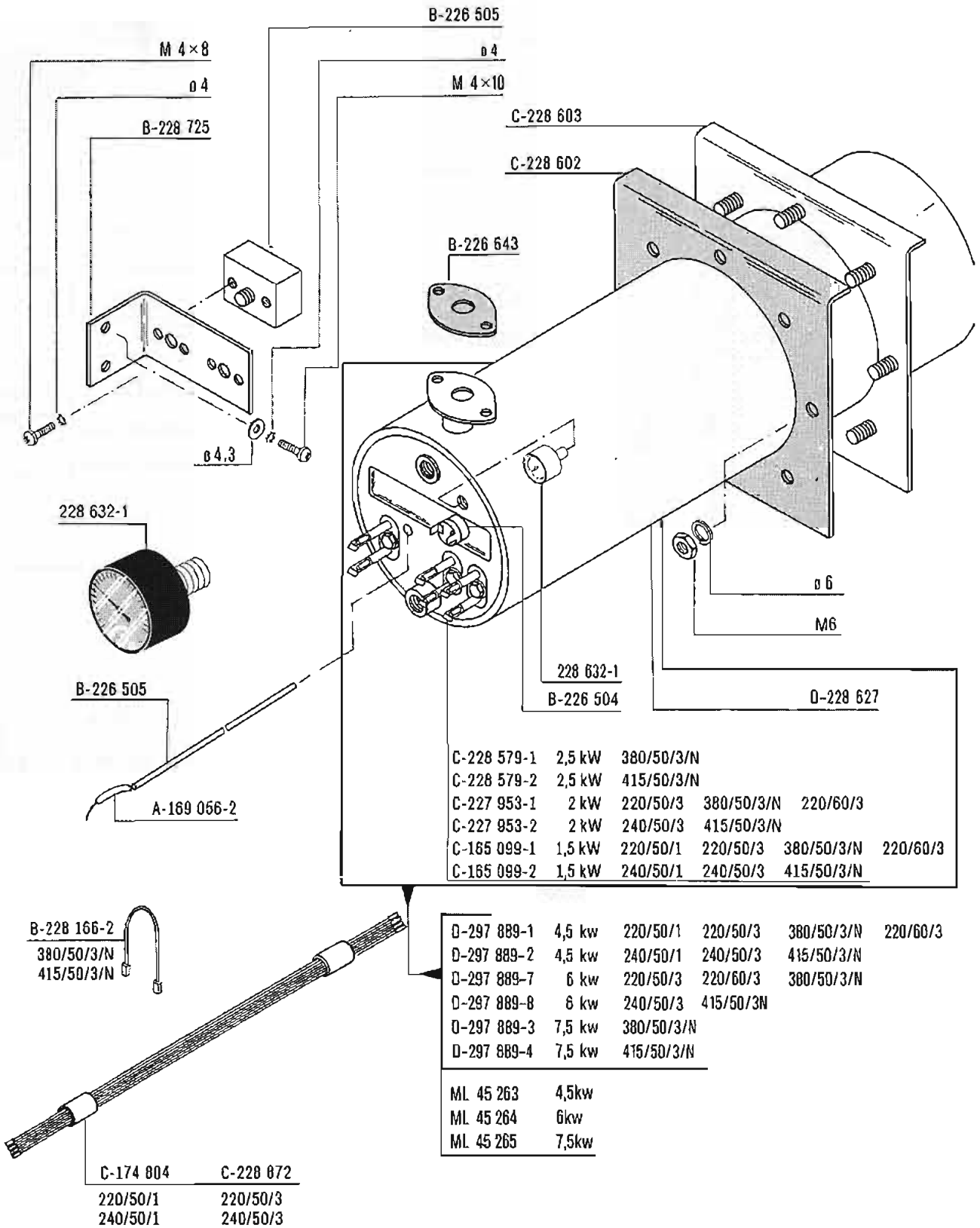

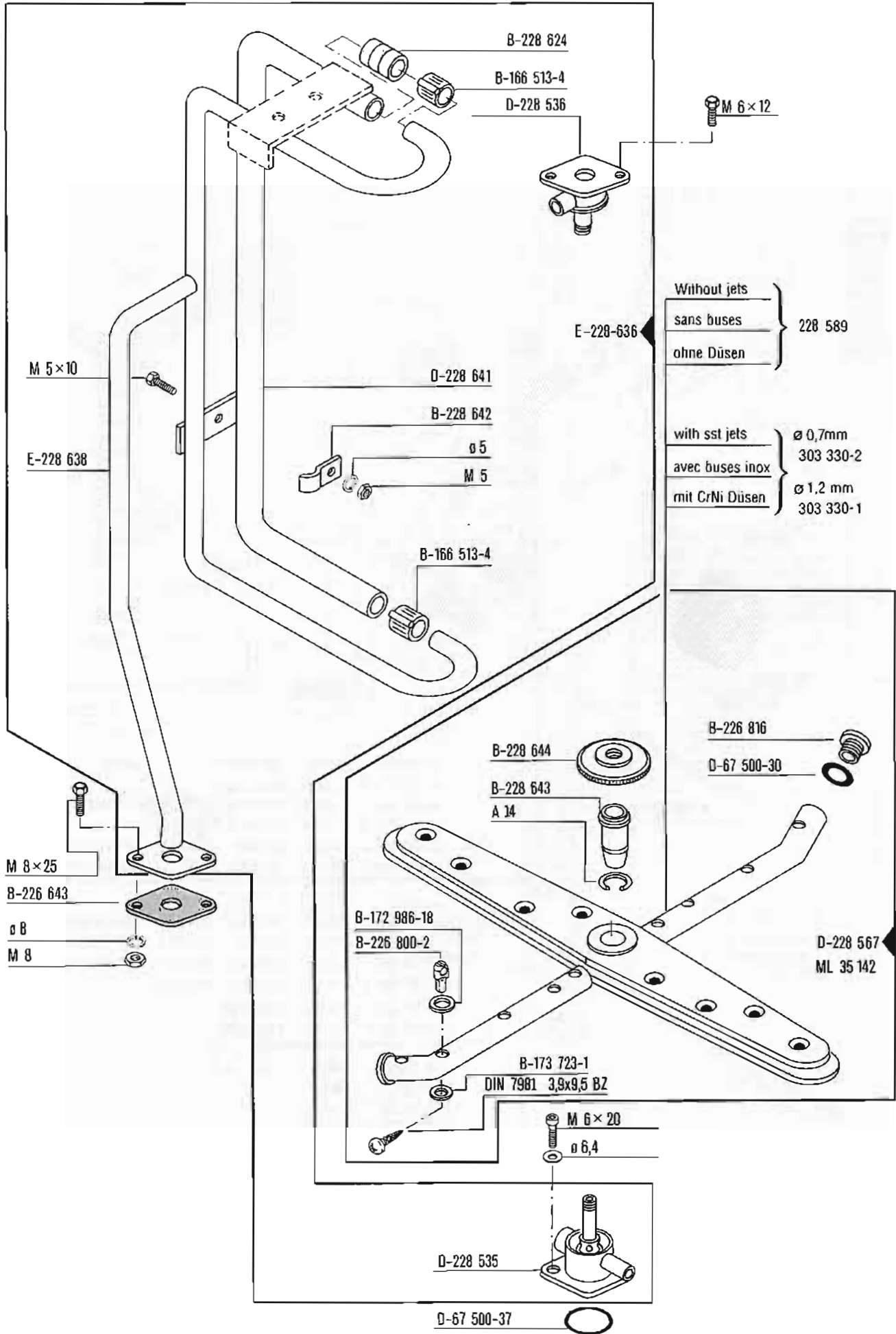

D-226 776-1	220/50/1	D-226 776-4	240-415/50/3/N
D-226 776-2	240/50/1	D-226 776-6	220/60/3
D-226 776-3	220-380/50/3/N		

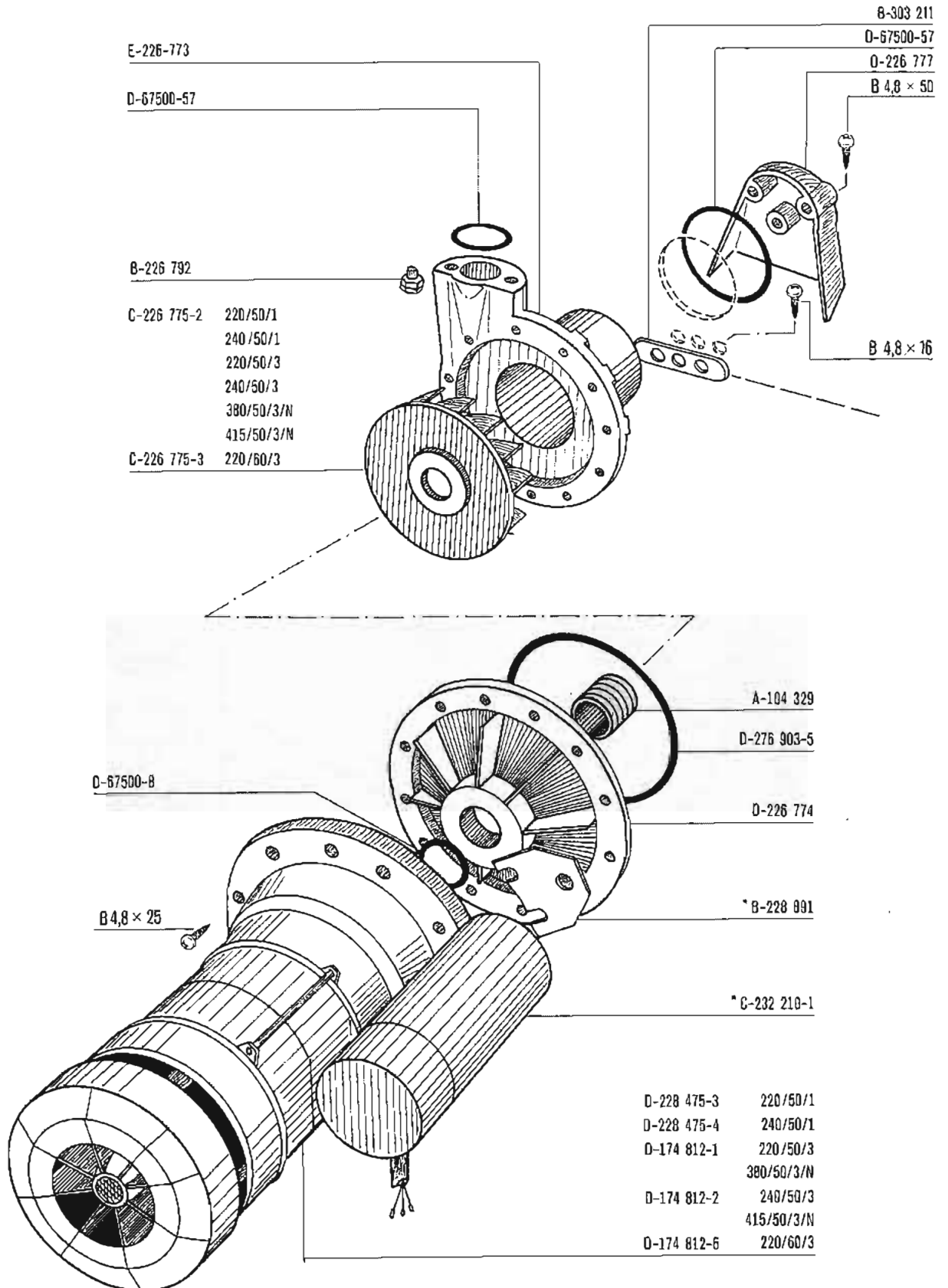

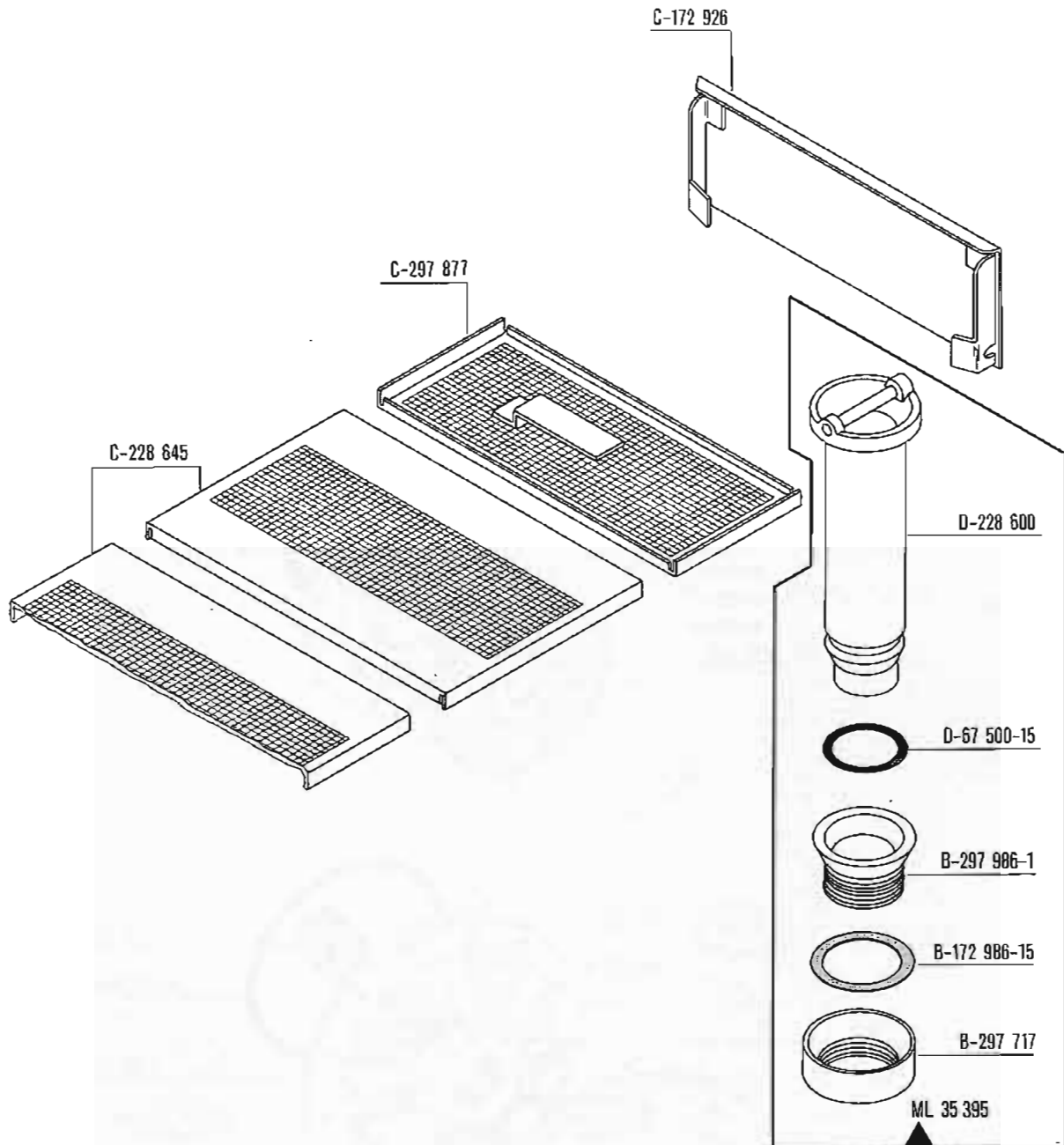

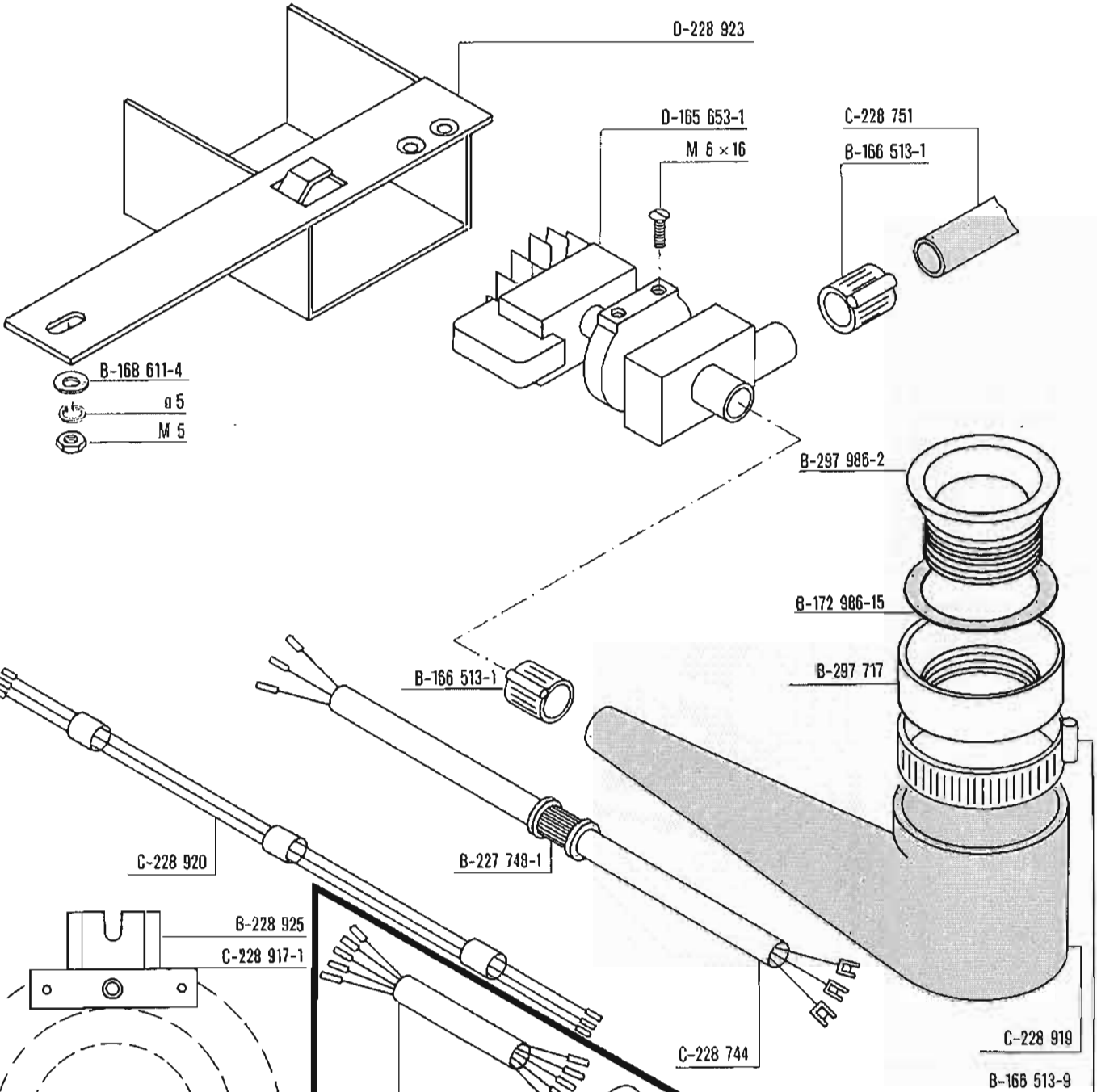

Wash pump
Pompe de lavage
Waschpumpe

B-174 811	220/50/3 240/50/3 220/60/3	7,5kw	B-174 972-2	220/50/3	240/50/3	220/60/3
B-174 810	380/50/3/N	4,5/6/7,5kw	B-174 972-1	380/50/3/N	415/50/3/N	
B-174 809	220/50/3 240/50/3 220/60/3	4,5kw	B-174 972-1	220/50/3	240/50/3	220/60/3
B-174 807	220/50/1	4,5/6/7,5kw	B-174 972-2	220/50/1	240/50/1	
B-174 808	220/50/3 240/50/3 220/60/3	6kw	B-174 972-2	220/50/3	240/50/3	220/60/3

B-279 723-1	220/50/3	220/60/3	240/50/3	7,5kw
B-279 723-2	380/50/3/N	415/50/3/N		
B-279 723-4	220/50/3	220/60/3	240/50/3	4,5kw
B-279 723-5	220/50/1	240/50/1	4,5kw	6kw
B-279 723-6	220/50/3	220/60/3	240/50/3	6kw

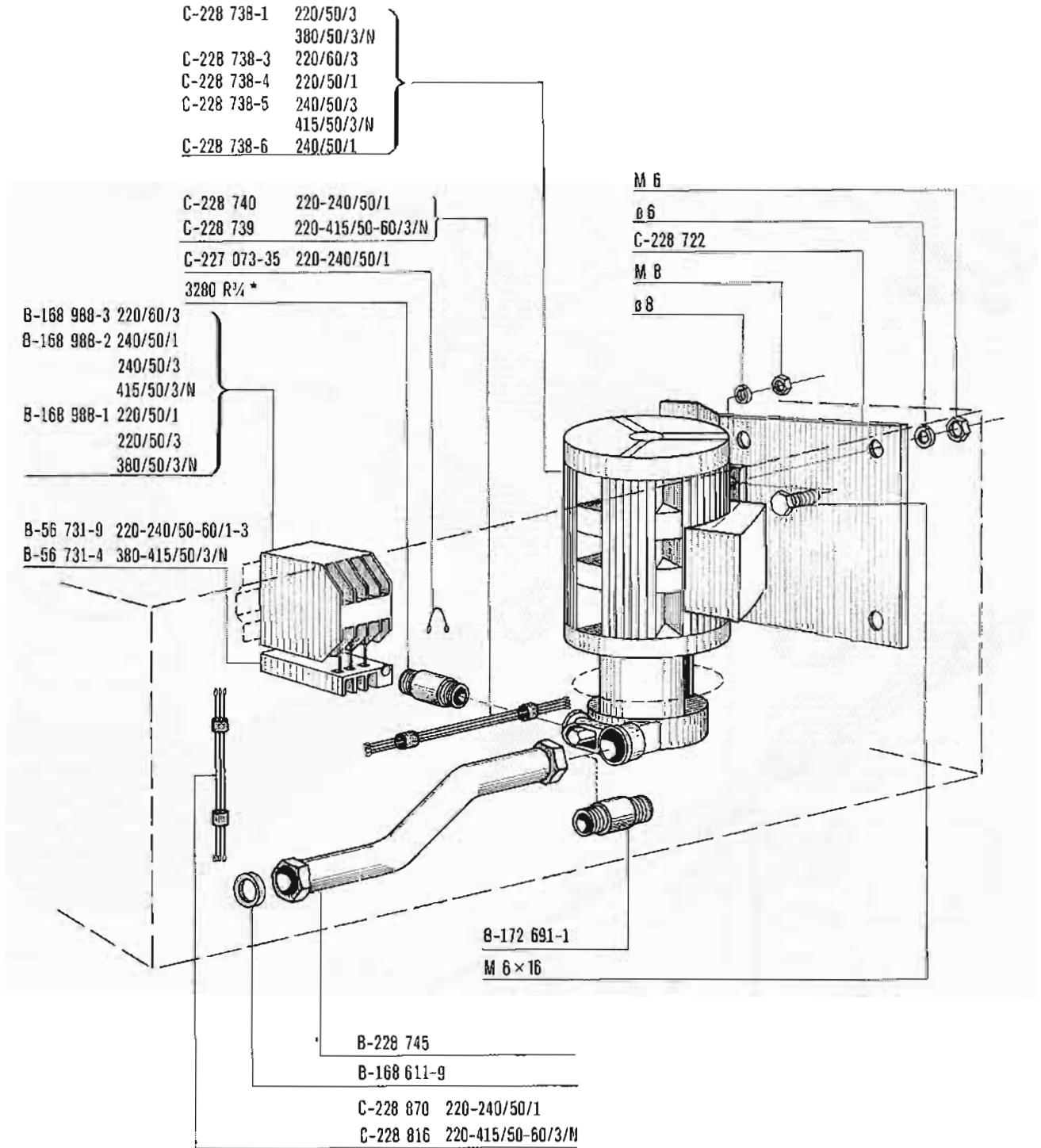

* with drain pump only
 sit. avec pompe de vidange
 nur bei Ablaufpumpe

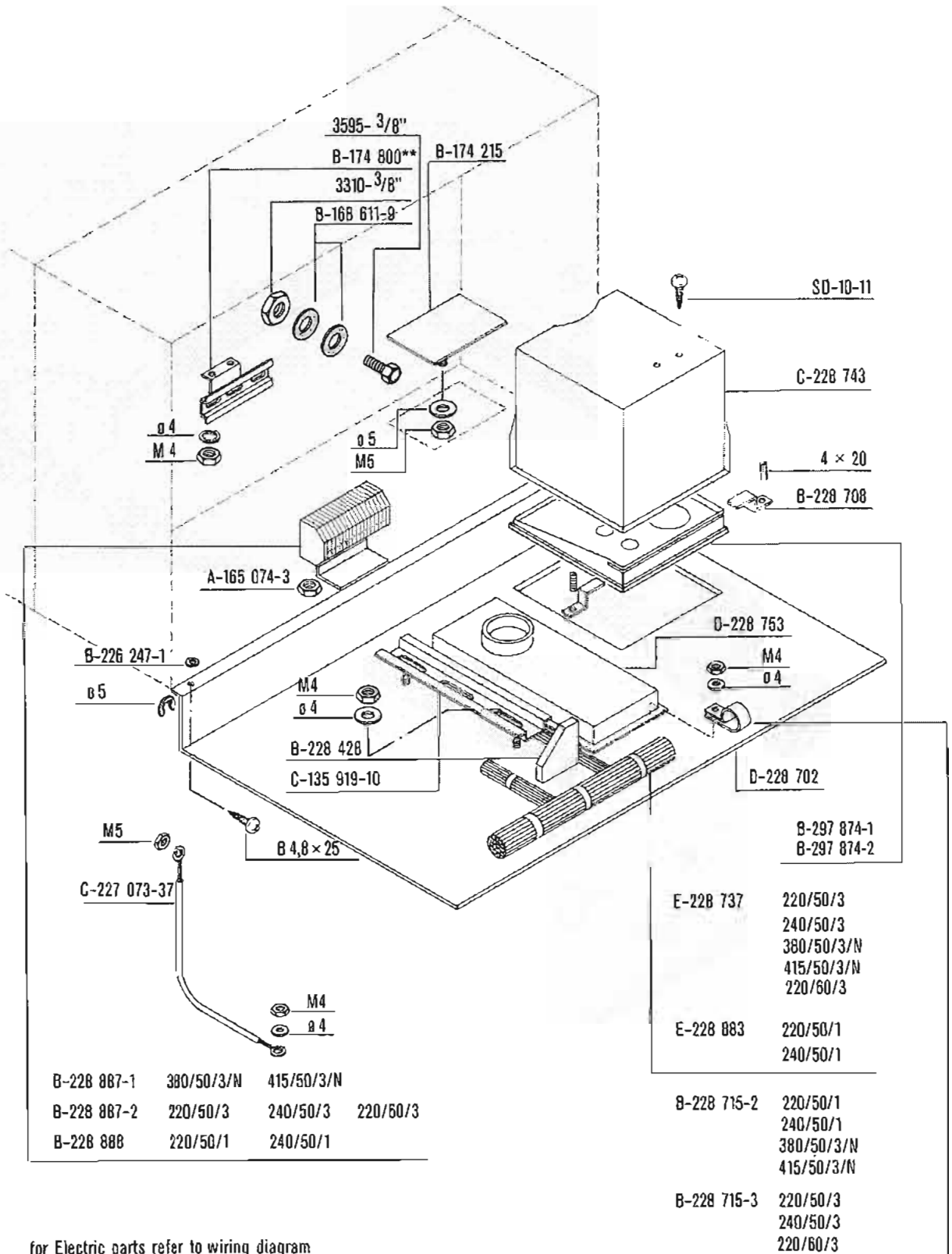

for Electric parts refer to wiring diagram
pièces électriques voir schéma électrique B-174 750
Elektroteile siehe Schaltplan

*with drain pump only
s'il. avec pompe de vidange
nur mit Ablaufpumpe

**with rinse pump or detergent dispenser only
s'il. avec pompe el. de pression ou doseur détergent
nur bei Drucksteigerungspumpe
oder Waschmitteldosiergerät

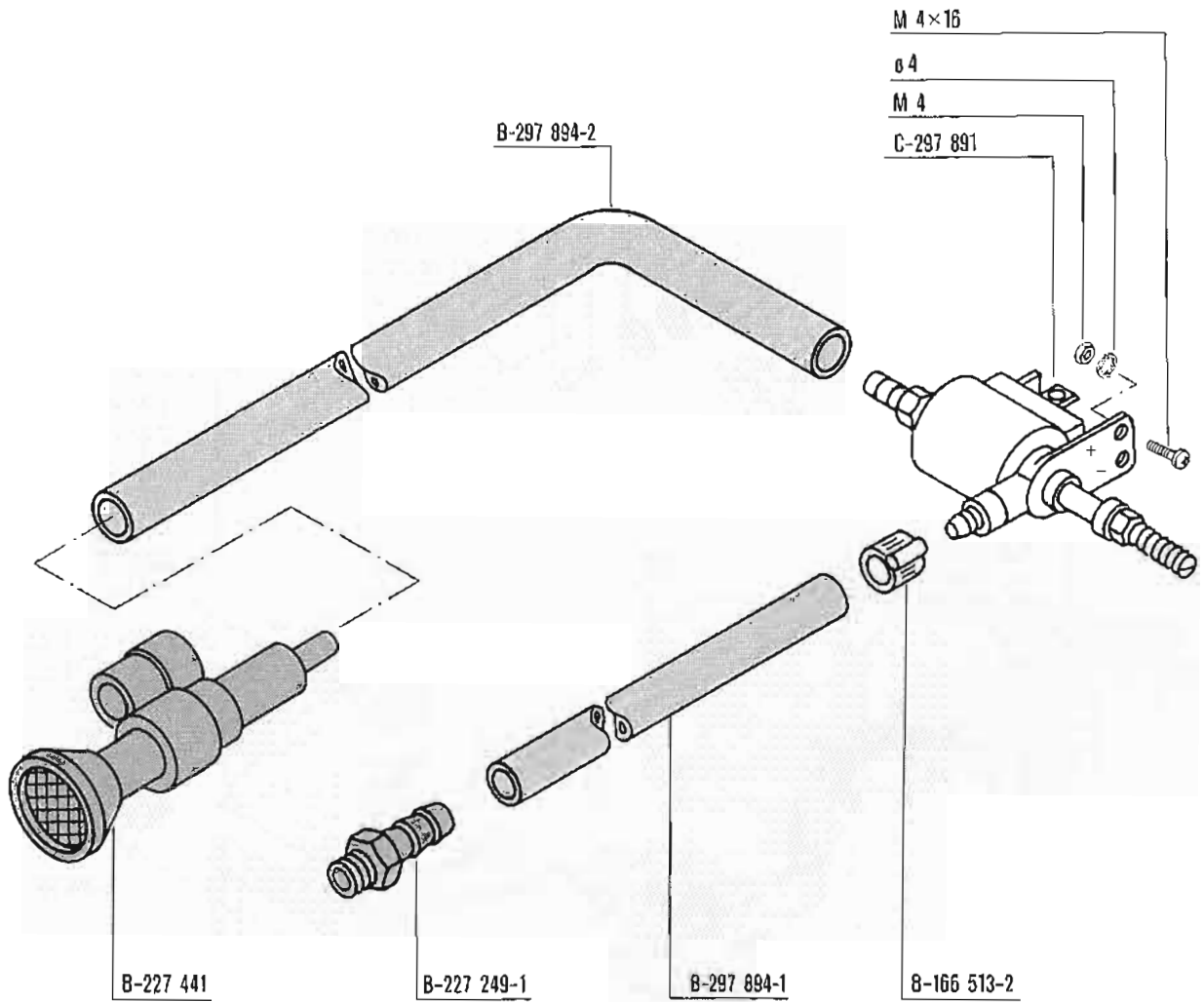

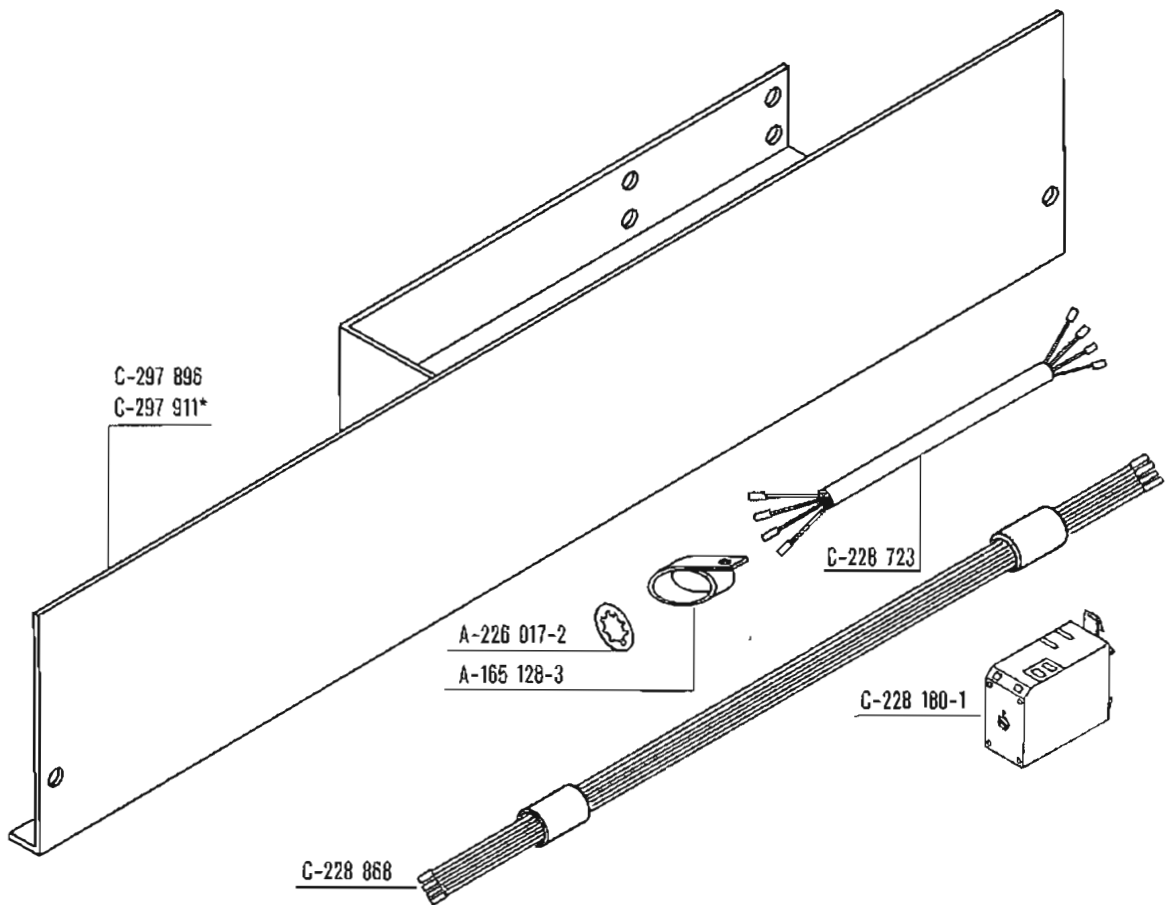
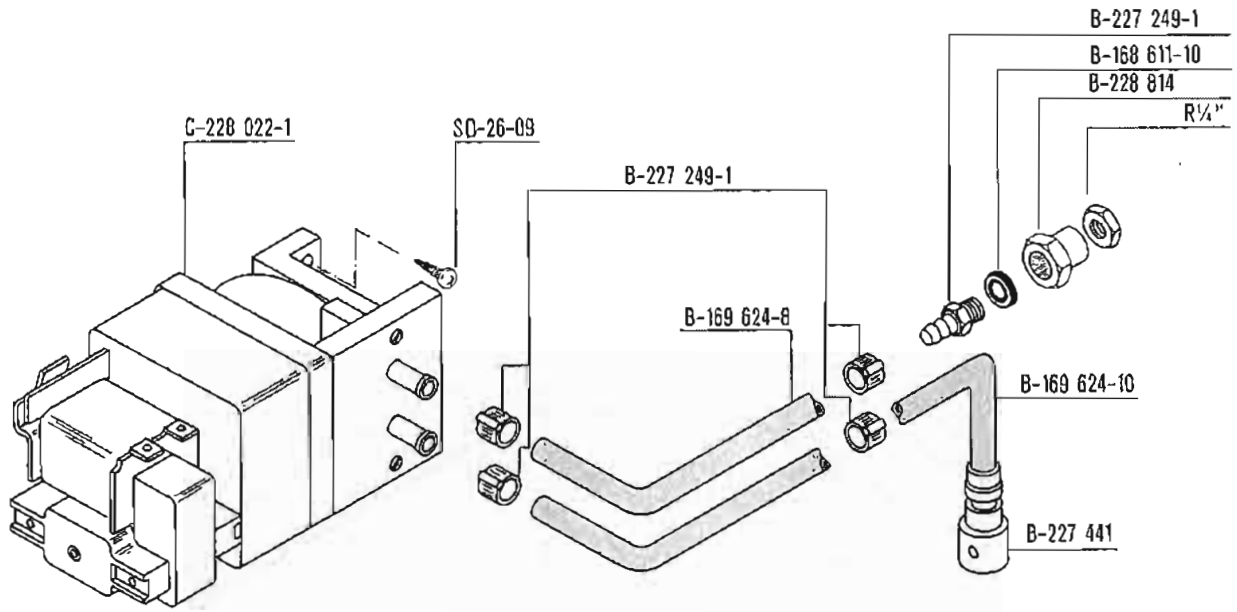



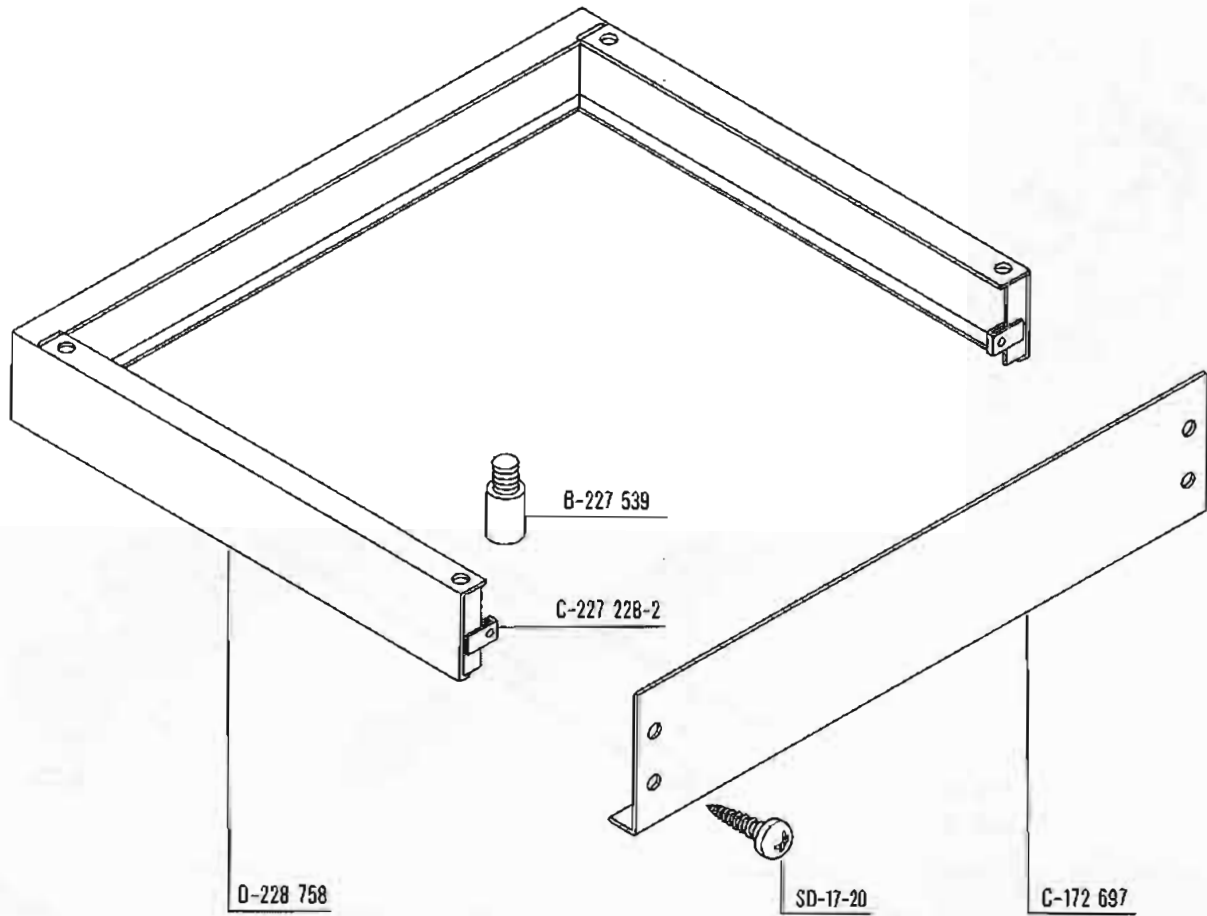

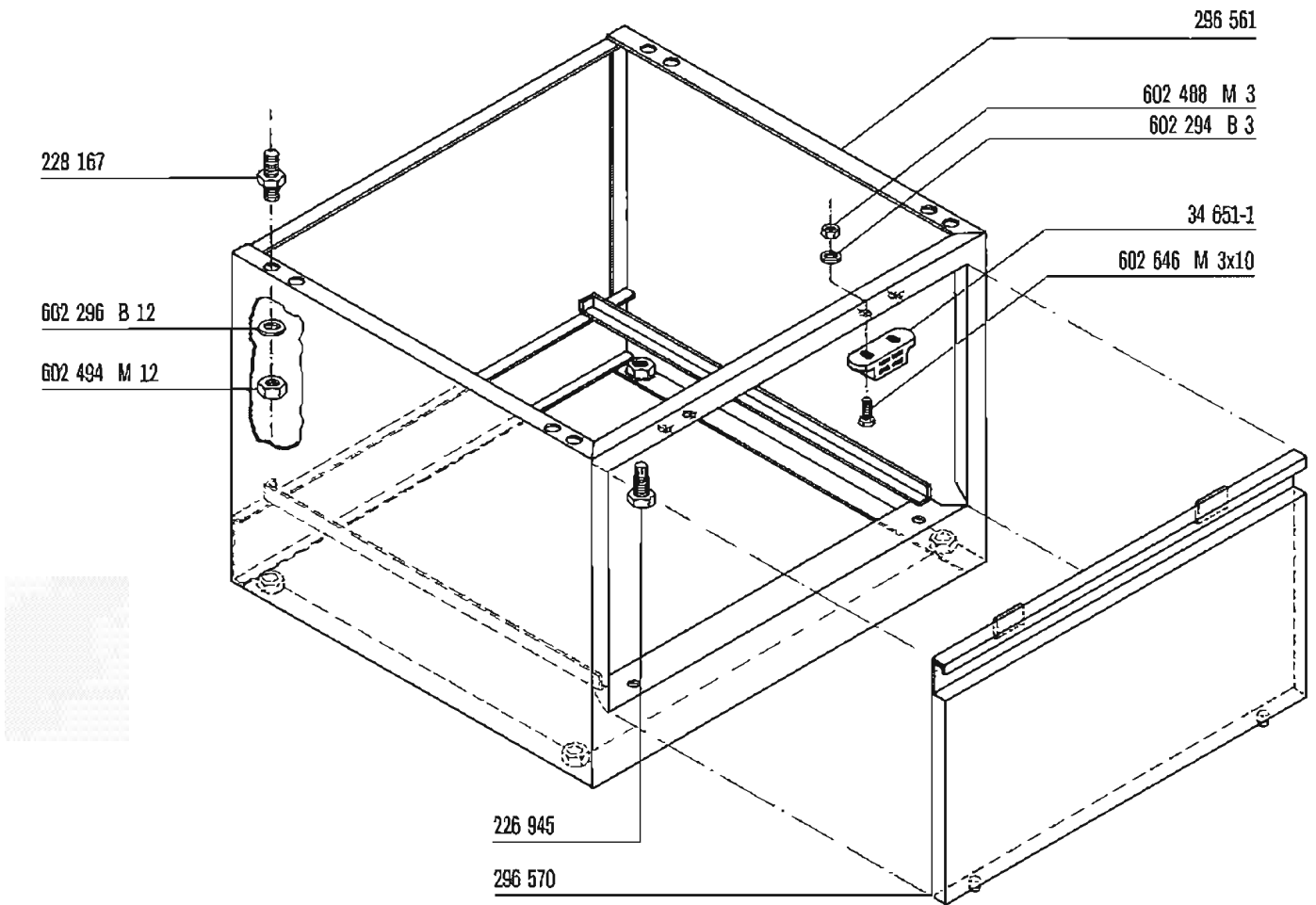





*900 mm machine height
900 mm hauteur de la machine
900 mm Maschinenhöhe





part pièces Teile	part name nom de la pièce Teile-Benennung
	hexagon head screw vis H Sechskantschraube DIN 933
	hexagon nut écrou H Sechskantmutter DIN 934
	washer rondelle Scheibe DIN 125
	lockwasher rondelle WZ Federring DIN 127
	self tapping recessed pan head screw vis à tôle avec tête bombée Linsen-Blechschaube DIN 7981
	recessed raised cheese head screw vis à tête bombée Linsenschraube DIN 7985
	recessed countersunk flat head screw vis à tête conique Senkschraube DIN 965
	snap ring jonc Runddraht-Sprengring DIN 7993
	slotted countersunk flat head screw vis à tête conique Senkschraube mit Schlitz DIN 963
	retaining washer rondelle d'arrêt Sicherungsscheibe DIN 6799